



SECURITY DOOR CONTROLS
 3580 Willow Lane
 Westlake Village, CA 91361
 (805) 494-0622 FAX (805) 494-8861
 www.sdcsecurity.com E-mail: service@sdsecurity.com

**SPECIAL APPLICATIONS POWER SUPPLY
 INSTALLATION INSTRUCTIONS**

MODEL 602RF

MODEL 602RF

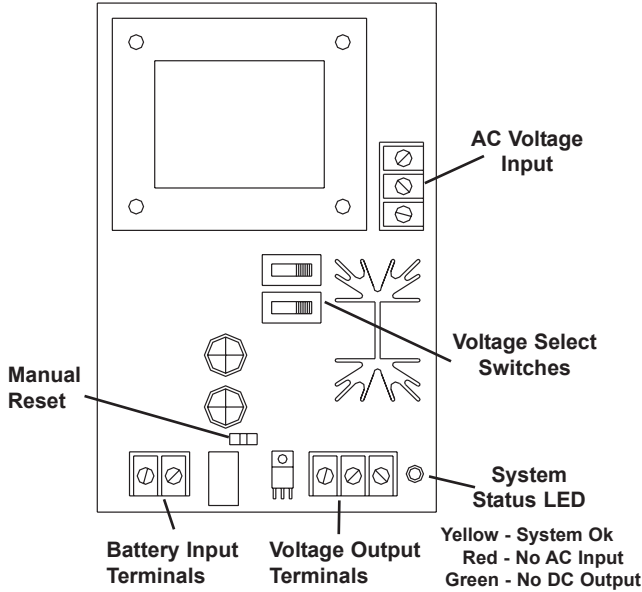

COMPONENT LOCATIONS

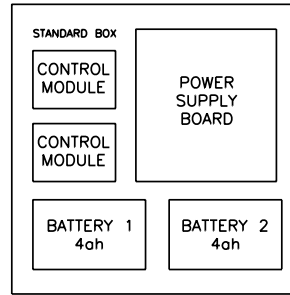

STANDARD BOX

**MAIN SYSTEM ON-OFF
 OR
 FIRE PANEL CONNECTION**

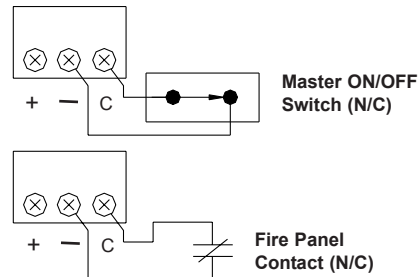

Min. Switch
 or
 Contact Ratings
 100ma. @ 30vdc

FIGURE C

POWER SUPPLY SPECIFICATIONS

Input Voltage: 115/230 VAC @ 60hz
Input Current: 0.8 amps Max.

Output Voltage: 12/24 VDC (Special Applications)
Burglary Use:

Output Voltage Ranges:
 12 V Operation: 9.2 - 12.0 VDC
 24 V Operation: 21.2 - 24.0 VDC

Output Current: 1.0 amps
Ripple Voltage: 0.05 Volts Max

Battery Charger Max Current: 0.25 amps
Maximum recommended battery size: 4ah
 (Replace batteries every 3 years.)

To determine standby battery capacity refer to
 Battery Discharge table (INST-BDT).

Compatible UL listed Fire Devices:
 Smoke detector manufactured by ESL, Model 521B,
 521BXT with Model 506 module.

Suitable Uses:
 Electric Lock Power Supply
 Access Control Power Supply
 Burglar Alarm System Power Supply
 Fire Protective Signaling Service

**NOT INTENDED TO POWER A LOCAL
 BURGLAR ALARM INDICATING DEVICE.**

TEST UNIT YEARLY

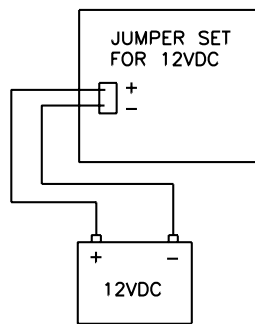

**12 Volt Mode Battery
 Connections**

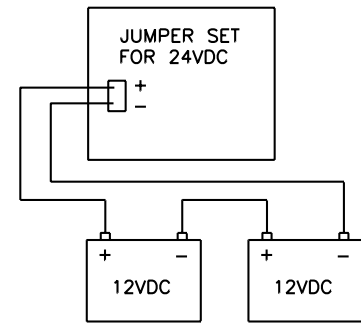

**24 Volt Mode Battery
 Connections**

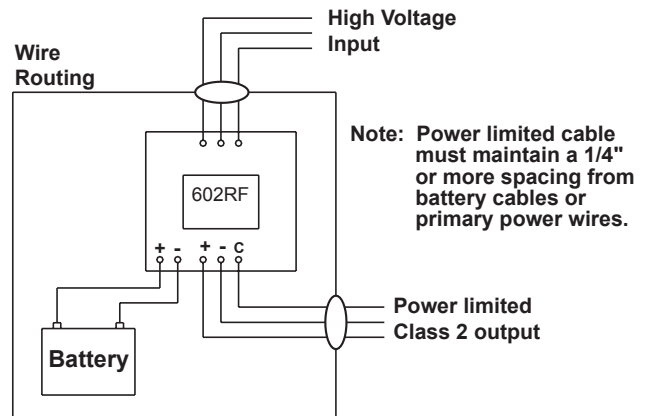



SECURITY DOOR CONTROLS
 3580 Willow Lane
 Westlake Village, CA 91361
 (805) 494-0622 FAX (805) 494-8861
 www.sdcsecurity.com E-mail: service@sdsecurity.com

**SPECIAL APPLICATIONS POWER SUPPLY
 INSTALLATION INSTRUCTIONS**

MODEL 602RF-CUL

MODEL 602RF-CUL

COMPONENT LOCATIONS

COVER

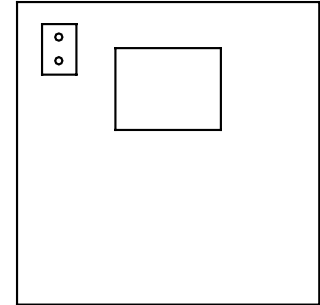
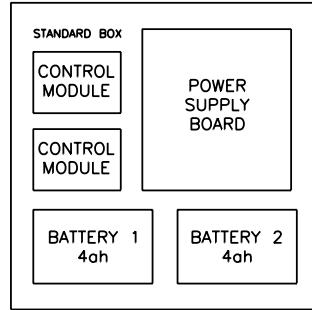
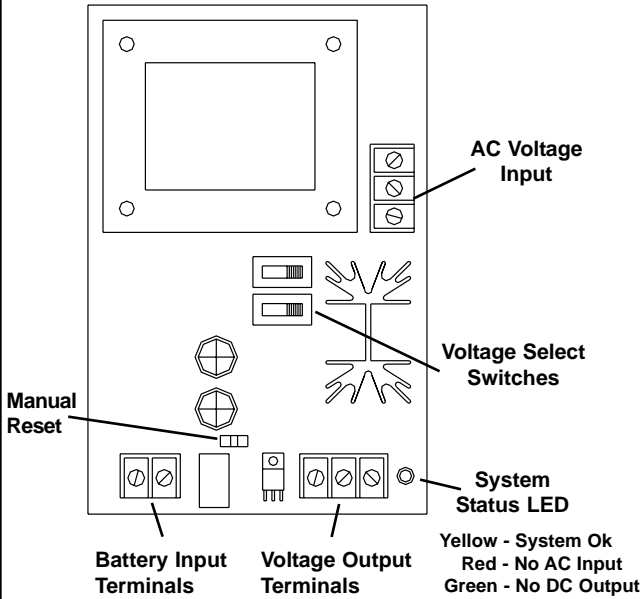

BATTERY MONITOR LEDS
 GRN = AC
 RED = BATTERIES
 ORG = LO/NO BATTERY

MAIN SYSTEM ON-OFF

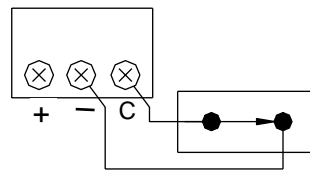

Min. Switch or Contact Ratings
 100ma. @ 30vdc

Master ON/OFF Switch (N/C)

POWER SUPPLY SPECIFICATIONS

Input Voltage: 115 VAC @ 60hz
Input Current: 0.8 amps Max.

Output Voltage: 12/24 VDC (Special Applications Burglary Use:

Output Voltage Ranges:
 12 V Operation: 9.2 - 12.0 VDC
 24 V Operation: 21.2 - 24.0 VDC

Output Current: 1.0 amps
Ripple Voltage: 0.05 Volts Max

Battery Charger Max Current: 0.25 amps
Maximum recommended battery size: 4ah
Recommended Battery: SDC Model RB12V4 (Replace batteries every 3 years.)

To determine standby battery capacity refer to Battery Discharge table (INST-BDT).

Suitable Uses:
Electric Lock Power Supply
Access Control Power Supply

TEST UNIT YEARLY

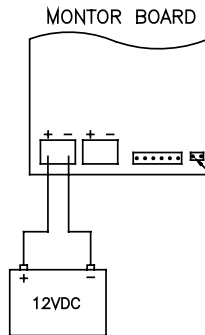

12 Volt Mode Battery Connections

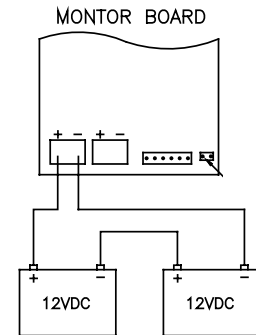

24 Volt Mode Battery Connections

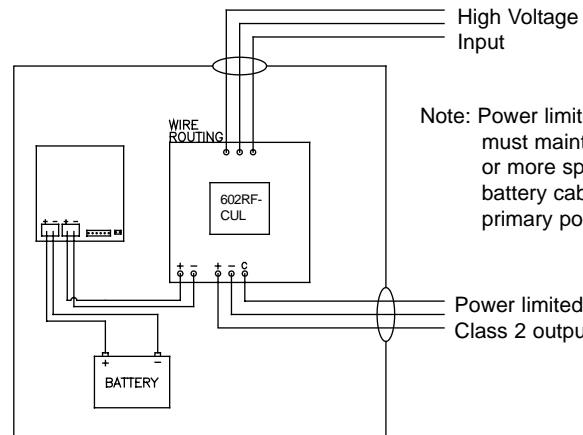

Note: Power limited cable must maintain a 1/4" or more spacing from battery cables or primary power wires.